

Nominal Pressure		1.6	Mpa
Testing Pressure	Shell	2.4	
	Sealing	1.76	

1. STANDARD MATERIALS OF MAIN PARTS

ITEM	PART NAME	MATERIAL
1	Body	Ductile Iron
2	Seat	EPDM
3	Shaft	SS420
4	Disc	Ductile Iron
5	Wedge Nut	Brass
6	Bonnet Gasket	EPDM
7	Bonnet	Ductile Iron
8	Sealing Ring	EPDM
9	Socket Head Screw	SS
10	Oring	EPDM
11	Hand Wheel	Ductile Iron

2. DIMENSIONS: (mm)

DN	F4 L	PN10				PN16			
		D	D1	D2	n-Ød	D	D1	D2	n-Ød
50	150	165	125	102	4-18	165	125	102	4-18
65	170	185	145	122	4-18	185	145	122	4-18
80	180	200	160	138	8-18	200	160	138	8-18
100	190	220	180	158	8-18	220	180	158	8-18
125	200	250	210	188	8-18	250	210	188	8-18
150	210	285	240	212	8-23	285	240	212	8-23
200	230	340	295	268	8-23	340	295	268	12-23
250	250	395	350	320	12-23	405	355	320	12-27
300	270	445	400	370	12-23	460	410	378	12-27
350	290	505	460	430	16-23	520	470	438	16-27
400	310	565	515	482	16-27	580	525	490	16-30
450	330	615	565	530	20-27	640	585	550	20-30
500	350	670	620	585	20-27	715	650	610	20-33
600	390	780	725	685	20-30	840	770	725	20-36

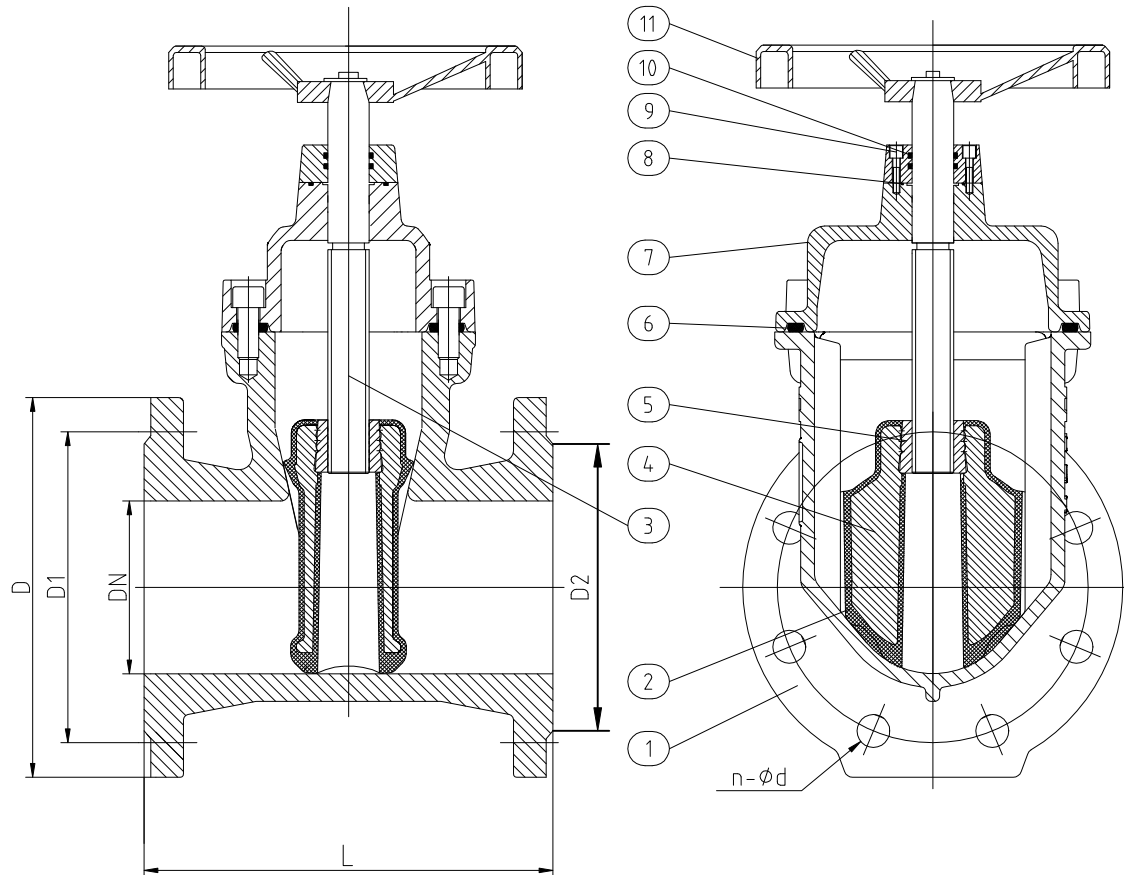

Gate Valve NRS Model: KN PLUS



DRAWING	X.L	CHECK	Q.L.S
---------	-----	-------	-------